

Dual-Fuel Built-In Ranges

EW30DS6CGS

Featuring Wave-Touch™ Electronic Controls



Min-2-Max™ Burner

Designed with a dual-flame sealed burner, this cooktop offers the widest range of BTU performance in the industry for the utmost versatility – from a roaring 18,000-BTU boil to a gentle 450-BTU simmer.



Sure-2-Fit™ Convection Oven with Hidden Bake Element

Adjustable Luxury-Glide™ oven racks are so smooth and extend effortlessly. Luxury-Design™ Lighting ramp-up designer halogen lighting is as beautiful as it is functional. Exclusive Luxury-Hold™ oven door stays put at whatever angle you place it.



Baking Options

Features 7 cooking modes and 10 cooking options including our exclusive Perfect Turkey™ button for large holiday meals. Perfect Convect3™ Third Element European Convection System features a variable 2-speed fan for more even cooking.



Perfect Pair™ Oven

Our ranges feature a large main oven and a second oven for the utmost cooking capacity. Use both simultaneously to cook two different items at two different temperatures.

30" DUAL-FUEL BUILT-IN RANGES

Sabbath Mode (Star-K® Certified)	Yes
Control Panel Features	
Wave-Touch™ Electronic Oven Control	Yes
Professional-Grade Burner Controls	Yes
Keypad Entry of Time & Temperature	Yes
Electronic Clock & Timer	Yes
Temperature Display	Yes
Automatic Oven (Delay, Cook & Off)	Yes
Cooktop Features	
Min-2-Max™ Dual-Flame Sealed Burner – 18,000 - 450 BTU	1
Sealed Power Burner – 14,000 BTU	1
Sealed Precision Burner – 9,500 BTU	1
Sealed Precision Burner – 5,000 BTU - 850 BTU	1
Linear Flow Burner Valves	Yes
Seamless Cooktop	Yes
Continuous Grates with Deep-Well Top	3
Electronic Pilotless Ignition	Yes
Oven Features	
Capacity	4.2 Cu. Ft.
Hidden Bake Element	Yes
Eight-Pass Bake Element – 2500 Watts	Yes
Eight-Pass Broil Element – 4000 Watts	Yes
Convection Element – 2500 Watts	Yes
Cobalt Blue Interior	Yes
Self-Clean Options with Door Lock	3
Perfect Convect3™ with Variable 2-Speed Fan	Yes
Cooking Modes – Bake, Broil, Convection Bake, Convection Roast, Convection Broil, Keep Warm, Slow Cook	7
Cooking Options – Perfect Turkey™, Defrost, Dehydrate, Bread Proof, My Favourites, Multi-Stage Cooking, Temperature Probe, Rapid Preheat, Delay Bake, Convection Convert	10
Luxury-Design™ Lighting with Dual 40W Halogen Bulbs	Yes
Luxury-Glide™ Racks	2
Conventional Racks	1
Convection Roasting Rack	Yes
Additional Features	
Luxury-Hold™ Oven Door	Yes
Extra-Large Glass Window	Yes
Perfect Pair™ Lower Oven	Yes
Adjustable Leveling Legs	Yes
Accessories	
Porcelain Broiler Pan and Insert	Included
Grill/Griddle	Included
Wok Ring – 318254307	Optional
Simmer Plate – 318254206	Optional
LP Conversion Kit	Included
Rear Filler Kit - 903113-901S	Optional
Side Panel Kit - 903102-901S	Optional
Backguard Kit - 903111-901S	Optional
Side Trim Kit - 903110-901S	Optional
Colour / UPC (0-57112)	
Stainless Steel (S)	09701-5
Specifications	
Oven Cavity Dimensions –	
Height	16-1/2"
Width	24-1/8"
Depth	18-1/32"
Overall Exterior Dimensions –	
Height (Adjustable)	36-7/16" – 37-7/16"
Width	31-1/2"
Depth (to Center of Arc) (with 90° Door Open)	28-5/16" 45-1/4"
Gas/Power Supply Connection Location	Right/Left Bottom Rear
Connected Load (kW Rating) @ 240/208 Volts	5.0/3.7
Amps @ 240/208 Volts	21.0/18.0
Minimum Circuit Required (Amps)	30
Product Weight	258 Lbs.
Shipping Weight (Approx.)	278 Lbs.

NOTE: Always consult local and/or national electric and gas codes. Refer to Product Installation Guide for detailed installation instructions on the web at www.electroluxappliances.ca. Specifications subject to change.

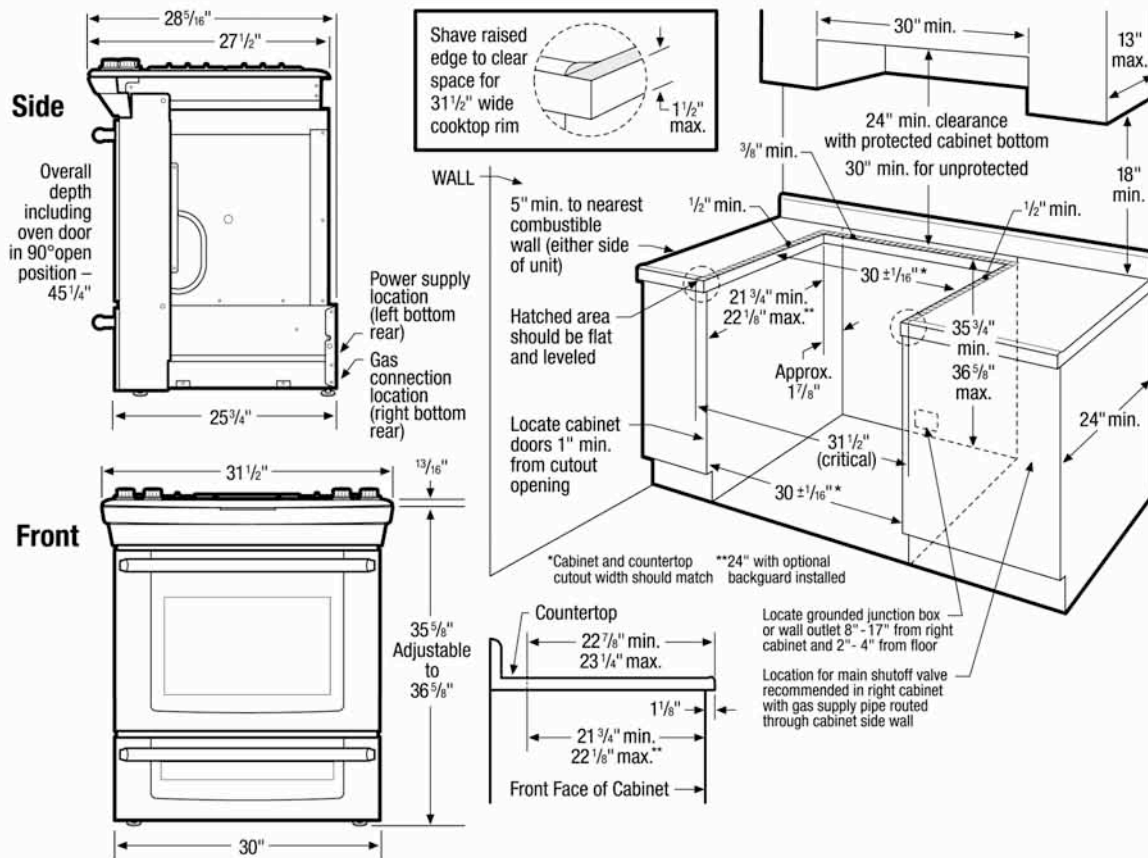

30" Dual-Fuel Built-In Range Specifications

- Product Weight – 258 Lbs.
- Single phase 3- or 4-wire cable, 120/240 or 120/208 Volt, 60 Hertz, fused on both sides of line with ground. (If local code permits, range may be connected by hard-wiring or by means of power supply cord kit.)
- Connected Load (kW Rating) @ 240/208 Volts = 5.0/3.7 kW
- Amps @ 240/208 Volts = 21.0/18.0 Amps
- Recommended Circuit Breaker – 30 Amps
- Always consult local and/or national electric and gas codes.
- Range ships with 3/4" factory regulator.
- Lp conversion kit supplied.
- Gas supply piping can be routed through side wall of right cabinet. Right side cabinet is ideal location for main shutoff valve.
- Countertop MUST be level in all directions and adjustable range height at least 1/16" greater than tallest cabinet height, to ensure metal rangetop flange will fit properly on countertop edge.
- When installing optional Backguard Kit, cutout depth of 21-3/4" minimum / 22-1/8" maximum needs increased to 24".
- Overhead cabinetry should not exceed a 13" maximum depth.
- Absolute minimum horizontal distance between overhead cabinets installed to either side of appliance must be no less than maximum width of appliance.
- Allow 24" minimum clearance between rangetop and bottom of cabinet when bottom of wood or metal cabinet is protected by not less than 1/4" flame-retardant millboard covered with not less than No. 28 MGS sheet steel, 0.015" stainless steel, 0.024" aluminum or 0.020" copper. Allow 30" minimum clearance when cabinet is unprotected.

- Allow 5" minimum clearance from edge of rangetop to nearest combustible wall on either side of unit.
- To reduce risk of fire when using overhead cabinetry, install range hood that projects horizontally a recommended minimum of 5" beyond bottom of cabinets.

Countertop Preparation

For detailed preparation instructions, refer to installation guide on the web.

- Flat square-finish (flat) countertop requires no preparation since rangetop flange lays directly on countertop edge.
- Formed front-edged countertops require front molded edge to be shaved flat 3/4" from each front corner of opening.
- Tile countertops may need cut back 3/4" from each front corner of opening and/or rounded edge flattened.
- For existing cutout width greater than 30-1/16" reduce the 3/4" overlap dimension or for cutout width of 29", replace actual side trim panels with smaller side trim panels, available with optional Side Filler Kit (refer to detailed kit installation instructions).

Note: For planning purposes only. Refer to Product Installation Guide on the web at electroluxappliances.ca or supplied with product for detailed instructions.

Optional Accessories

- Wok Ring – (318254307).
- Rear Filler Kit: S – (903113-901S).
- Backguard Kit: S – (903111-901S).
- Simmer Plate – (318254206).
- Side Panel Kit: S – (903102-901S).
- Side Trim Kit: S – (903110-901S).